



Ball State University

ASHRAE

Paradigm Shift: Burning Coal to Geothermal

February 21, 2012

jlowe@bsu.edu

JeffU@mepassocites.com

Ball State University

Founded in 1918

7.1 M square feet

731 acres

22,000 students



Heat Plant and Chilled Water Plant Operations

Heat Plant:

4 Coal Fired Boilers

3 Natural Gas Fired Boilers

320,000 Lbs/Hr nameplate capacity

240,000 Lbs/Hr current capacity

700,000,000 Lbs/Year

Chilled Water Plant:

5 Electrical Centrifugal Chillers

9,300 ton capacity

25,000,000 Ton Hours/Year



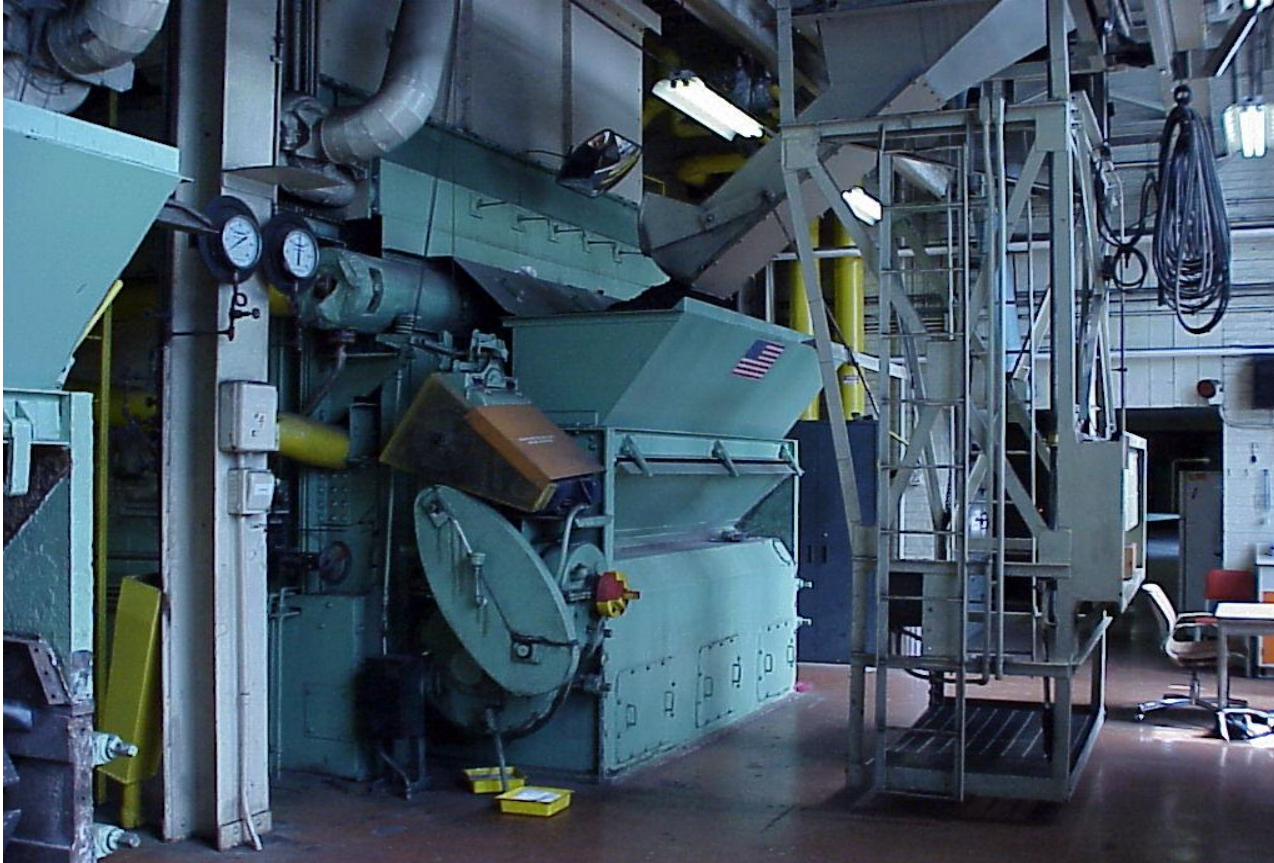

(4) stoker coal fired boilers

(2) installed 1941

(2) installed 1955

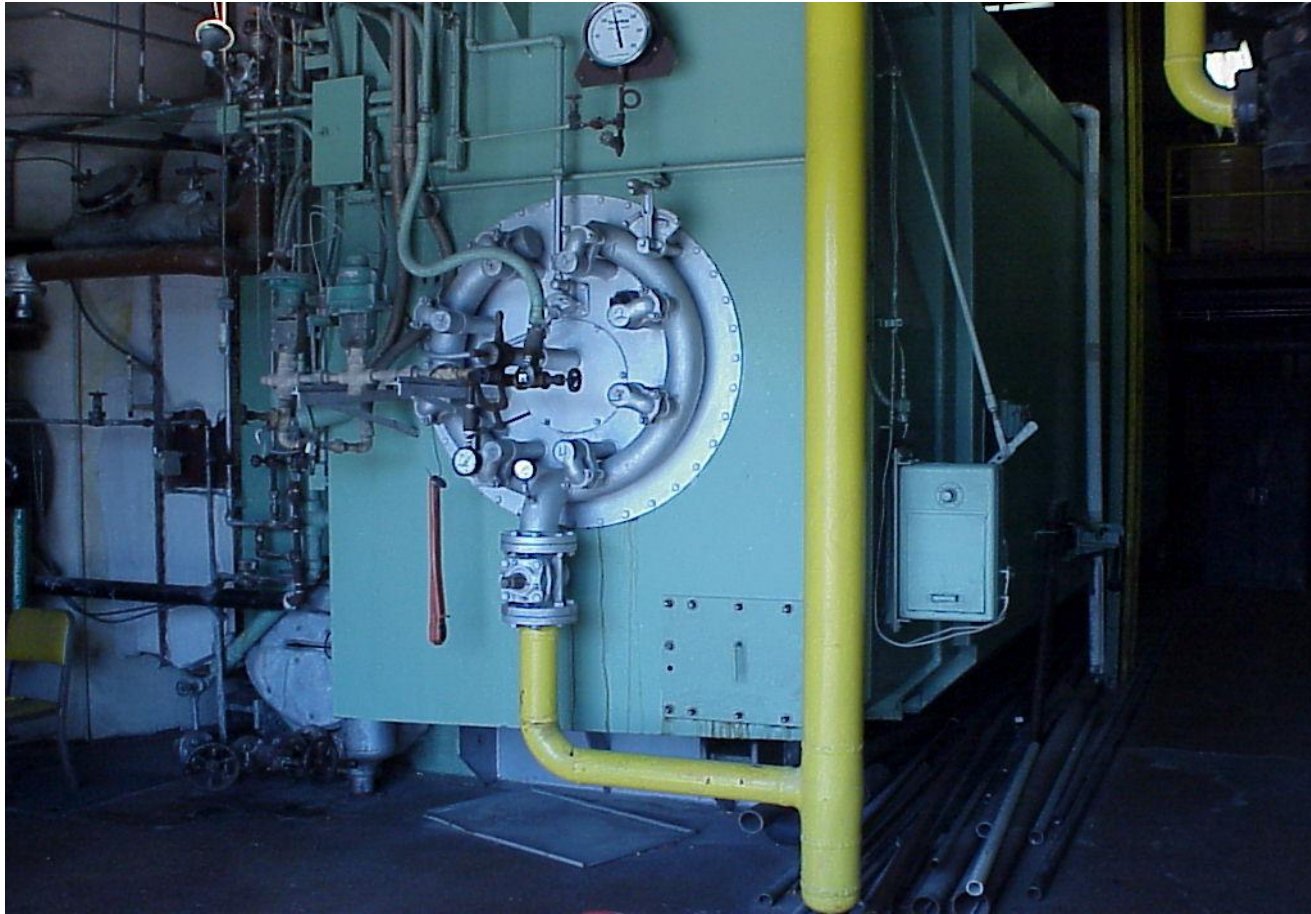

(3) Natural Gas Fired Boilers

(2) installed in late 1960s

(1) installed in 1970

Ball State Annual Utility Use

- Coal 36,000 tons
- Electricity 110,000,000 kwh
- Natural Gas 150,000,000 cf

Pollutants Produced from Burning Coal

- Carbon Dioxide 85,000 tons (Global Warming)
- Sulfur Dioxide 1,400 tons (Acid Rain)
- Nitrogen Oxide 240 tons (Smog)
- Particulate Matter 200 tons (Breathing)
- Carbon Monoxide 80 tons (Headache)

Coal-fired Boiler Replacement

- Condition: Average age over 64 years old
- Capacity: Campus grew in size, boiler output degraded, output limited by Title V operating permit
- EPA regulations: Boiler Maximum Achievable Control Technology

Circulating Fluidized Bed Boiler

- Estimated Cost \$65 - \$70 million
- Equipment made in China
- Ten story structure
- Burn 70% fossil fuel with 30% alternative fuels
- Approximately 15% more efficient

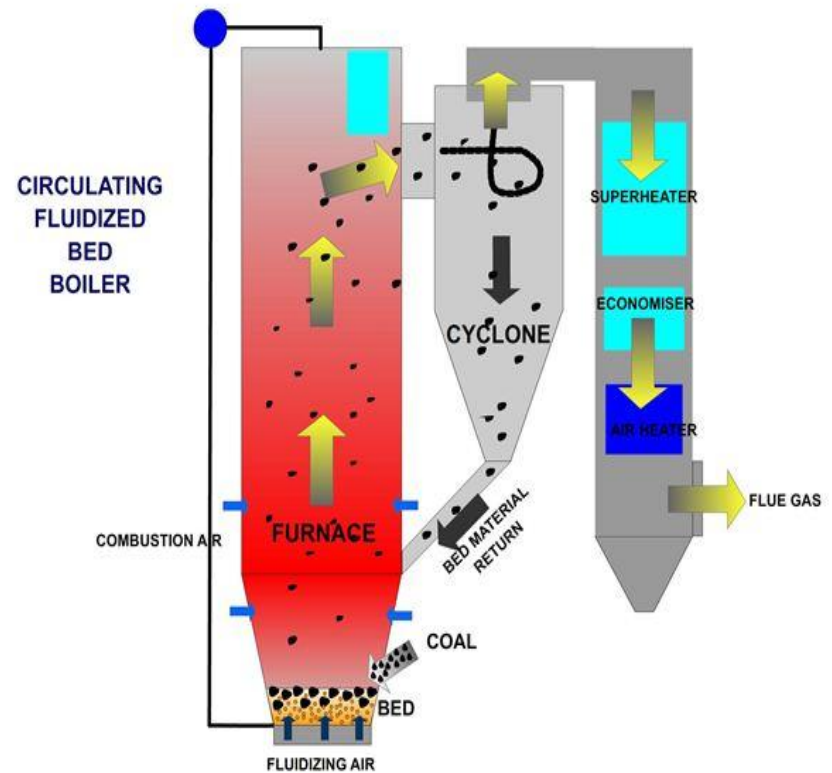

Primary Energy Use by Source, 2009,

Quadrillion Btu and Percent

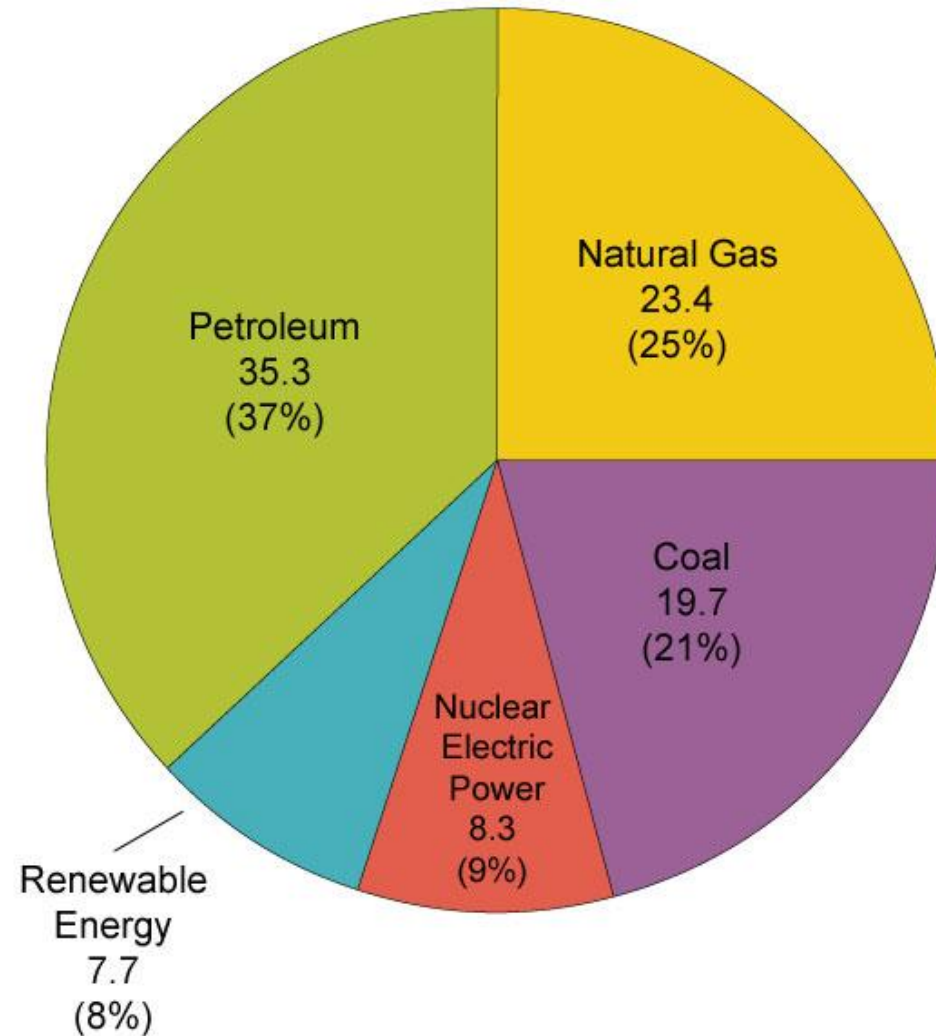

Source: U.S. Energy Information Administration, *Annual Energy Review 2009*.

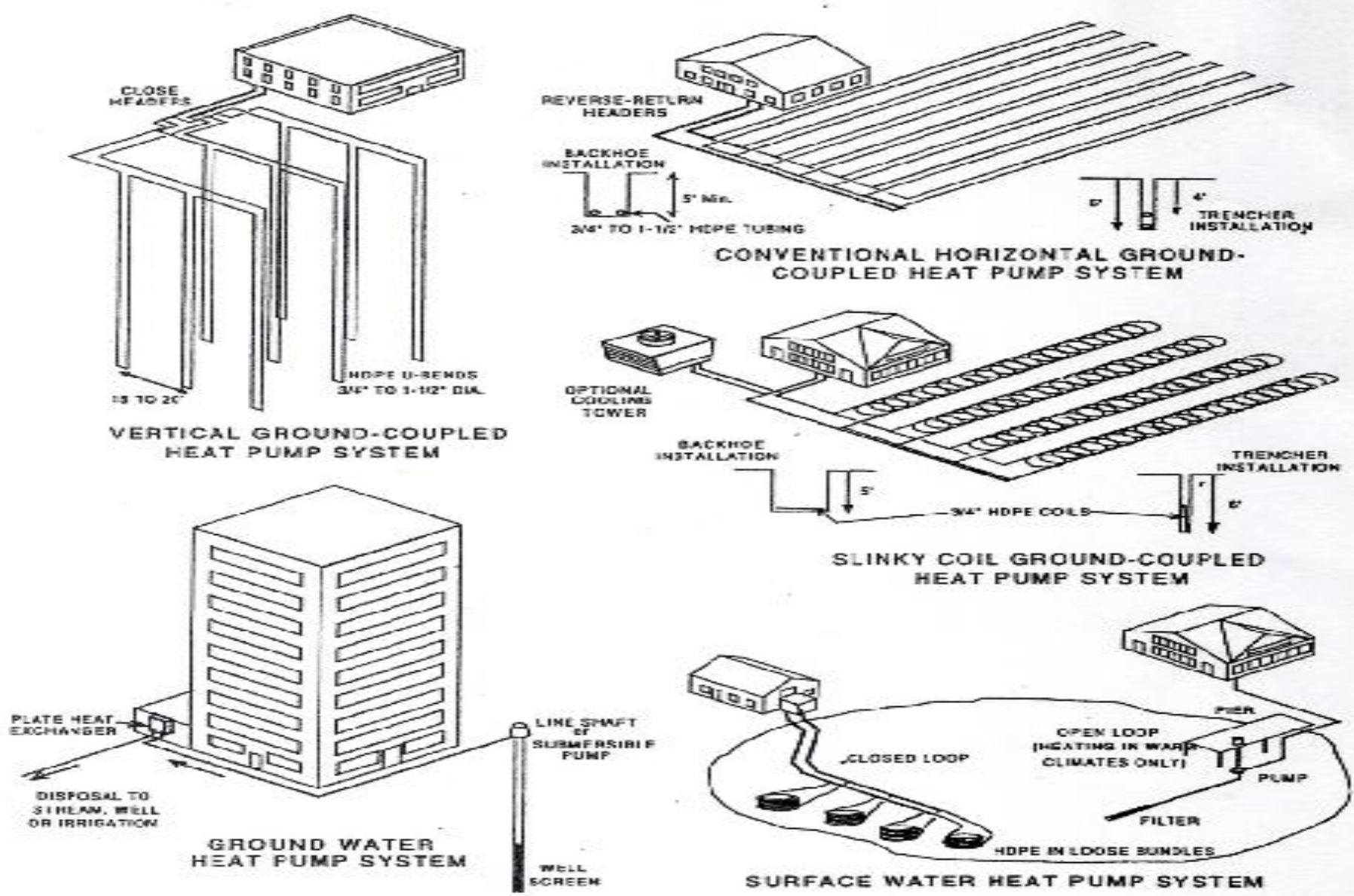
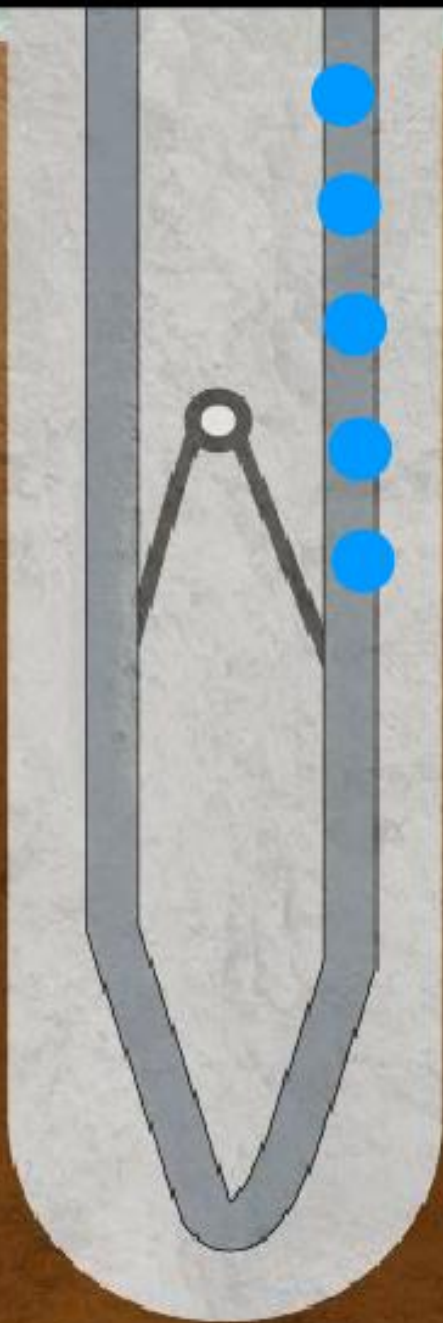

Figure 1.1 Ground-source (or geothermal) heat pump types.



When hot water is run through the pipes, the temperature of the ground cools the water.

Heat exchange

In the winter, the heat from the ground is picked up by the water and distributed from the thermal stations to buildings across campus.

In the summer, the process is reversed—hot water is pumped into the ground to cool off.

Law of Thermodynamics

- energy (heat) moves from a **warmer** area to the **cooler** area
- *Summer:* water entering the loop field is “**warmer**” than the ground--- heat moves from **(warm) water** to the **(cool) ground**
- *Winter:* water entering the loop field is “**cooler**” than the ground---heat moves from **(warm) ground** and to the **(cool) water**

Laws of Thermodynamics

“Engineers Holy Grail”

Zeroth law: “Thermal equilibrium”

if two thermodynamic systems are each in thermal equilibrium with a third system, then they are in thermal equilibrium with each other.

First law: “Conservation of energy”

energy can neither be created nor destroyed. It can only change forms.

Second law: “Energy flows from higher to lower temperature objects”

heat can spontaneously flow from a higher temperature region to a lower temperature region, but not the other way

Third law: “Minimum Kinetic Energy”

As temperature approaches absolute zero, the molecular kinetic energy of a system approaches a minimum, 0 degrees K, -273.15 degree C or -459.67 degree F.

Campus Heating and Cooling Loads

- Building Heating Loads (Mbtuh)
- Hot Water Flow (GPM)
- Building Cooling Loads (Tons)
- Chilled Water Flow (GPM)

APPENDIX A: HEATING AND COOLING LOADS

Building Name	Address	Year Built	Area (sq')	Heating Load (MBtuh)	Hot Water (gpm)	Cooling Load (tons)	Chilled Water (gpm)
Carmichael Hall	1701 W. McKinley	1967	22,963	574	38	58	138
Jolman Hall (Lebanese/Arabic/Israeli)	1801 N. McKinley	1987	292,432	5,561	437	141	388
LaFollette Halls (Village Expansion)	1515 N. McKinley	1954	531,792	13,295	886	211	537
Lewislin Pool	1400 N. McKinley	1967	56,415	1,410	94	0	0
Health/Phys Activ/Elec Building	1740 W. Neely	1989	110,710	2,768	185	186	445
Living Gymnasium	1700 W. Neely	1982	136,039	3,376	225	186	445
Worthen Arena		1990	198,267	4,832	322	448	1,075
Architecture	1212 N. McKinley	1970	146,750	3,669	245	333	799
Sub totals				36,484	2,432	1,582	3,748
Robert P. Bell Building	1211 N. McKinley	1982	105,500	2,663	178	141	388
David Lattaman Building	1201 N. McKinley Ave	2005	86,351	2,159	144	128	307
Edmund F. Ball Building	1159 N. McKinley	1986	84,594	2,115	141	256	614
Arts and Journalism Building	1101 McKinley	2000	237,141	5,179	345	218	522
Bracken Library	1100 N. McKinley	1972	321,800	8,045	636	640	1,536
University Theatre	920 N. McKinley	1960	83,667	2,092	139	179	430
Teachers College Building	901 N. McKinley	1966	125,650	3,141	209	288	691
Noyer Hall	1601 W. Neely	1982	238,320	5,958	397	448	1,075
Woodworth Halls	1600 W. Riverside	1956	184,628	4,116	274	202	484
Fruis Hall	1000 N. McKinley	1971	18,170	454	30	128	307
Bracken House	2200 W. Benwyn Rd.	1937	13,227	331	22	19	46
Whitinger Business Building	1200 N. McKinley	1978	93,783	2,344	156	160	384
Studebaker Halls East	1301 W. Neely	1965	97,408	2,435	162	51	123
Studebaker Halls West	1401 W. Neely	1964	242,080	6,052	403	294	707
Park Hall	1550 Riverside	2006	194,600	4,865	324	282	676
Music Building	1810 W. Riverside	1956	45,036	1,126	75	83	200
Music Instruction Building	1809 W. Riverside	2003	86,179	2,154	144	179	430
Emanis Auditorium	1800 W. Riverside	1983	82,101	2,053	137	243	594
Arts and Communication Bldg.	1701 W. Riverside	1957	47,010	1,176	78	83	200
Health Center	1500 W. Neely	1982	19,527	488	33	32	77
DeHorty Halls	1500 W. Riverside	1960	138,140	3,454	230	205	482
North Residence Hall	1400 W. Neely	2008	190,480	4,762	317	230	583
Sub totals				67,159	4,477	4,490	10,775
North Quad	1501 W. Riverside	1926	126,543	3,164	211	294	707
Applied Technology	2000 W. Riverside	1948	93,274	2,332	155	205	482
Fine Arts Building	2021 W. Riverside	1935	74,085	1,852	123	198	478
Cooper Physical Sciences	2111 W. Riverside	1965	130,090	3,252	217	461	1,106
Cooper Nursing	2111 W. Riverside	1965	47,580	1,190	79	122	292
Cooper Life Sciences	2111 W. Riverside	1968	113,843	2,848	190	442	1,080
Ball Gymnasium	Campus Drive	1939	83,197	2,080	139	115	276
West Quad	2801 W. Riverside	1936	57,593	1,440	96	109	261
Ludma Hall	2120 W. University	1927	60,014	1,500	100	128	307
Burris School	2201 W. University	1928	130,745	3,269	218	250	599
Elliott Dining	2100 W. Gilbert	1990	13,228	331	22	45	108
Wagoner Halls	301 N. Talley	1957	75,680	1,892	126	13	31
Elliott Hall	401 N. Talley	1937	51,627	1,291	86	32	77
Administration Building	2000 W. University	1912	54,136	1,353	90	96	230
Student Center	2001 W. University	1951	171,165	4,279	285	410	983
Burkhardt Building	801 N. McKinley	1924	61,439	1,536	102	70	169
Sub totals				33,698	2,240	2,399	7,173
Central Chiller	West Campus Drive	1965	7,909	198	13		
Field Sports Building	1720 W. Neely	1983	47,736	1,193	80		240
Greenhouses	Christy Woods	1965	4,381	110	7		
Heating Plant	2831 W. Riverside	1924	18,685	467	31		
South Service Bldg.	Campus Drive	1967	4,800	120	8		30
Expansion			300,000	7,500	500	640	1,500
Total			5,873,458	144,740	9,650	9,680	23,196

Conductivity Test

- Actual completed borehole with loops installed
- Water circulated through loop as heat is input and temperature of water measured over time
- Designed for 1.51 Btu/hr-ft-F
- Actual tested average of 2% of the 1,800 installed boreholes was 1.91 Btu/hr-ft-F
- Equates to a capacity of about 2.5 tons per borehole

APPENDIX C: BOREHOLE DESIGN REPORT

Borehole Design Software

Inputs

- Conduct-Ground/Grout
- Cooling Loads-Total/Peak
- Heating Loads-Total/Peak
- Flow Rates
- Double/Single loop
- Borehole Spacing
- Water Temp- Heat/Cool

Output

- Total Feet Borehole

Ground Loop Design

Borehole Design Project Report - 1/14/2009



Project Name: Ball State	
Designer Name: Jeff Ucholski	Project Start Date: 12/9/2008
Date: 12/9/2008	
Client Name: Ball State	
Address Line 1:	
Address Line 2:	
City:	Phone:
State:	Fax:
Zip:	Email:

Calculation Results

	COOLING	HEATING
Total Length (ft):	132234.6	145234.0
Borehole Number:	375	375
Borehole Length (ft):	352.6	387.3
Ground Temperature Change (°F):	+1.2	+1.1
Unit Inlet (°F):	85.0	45.0
Unit Outlet (°F):	95.2	38.3
Total Unit Capacity (kBtu/Hr):	11119.7	12692.9
Peak Load (kBtu/Hr):	8418.7	12692.9
Peak Demand (kW):	674.3	617.7
Heat Pump EER/COP:	12.5	3.6
System EER/COP:	12.5	6.0
System Flow Rate (gpm):	2104.7	3173.2

Input Parameters

Fluid		Soil	
Flow Rate:	3.0 gpm/ton	Ground Temperature:	55.0 °F
Fluid:	100% Water	Thermal Conductivity:	1.68 Btu/(h*ft*°F)
Specific Heat (Cp):	1.00 Btu/(°F*lbm)	Thermal Diffusivity:	1.12 ft²/day
Density (rho):	62.4 lb/ft³		
Piping			
Pipe Type:	1 in. (25 mm)		
Flow Type:	Turbulent - SDR11		
Pipe Resistance:	0.021 h*ft³/Btu		
U-Tube Configuration:	Double		
Radial Pipe Placement:	Along Outer Wall		
Borehole Diameter:	6.00 in		
Grout Thermal Conductivity:	0.84 Btu/(h*ft*°F)		
Borehole Thermal Resistance:	0.156 h*ft³/Btu		

Borehole Field Design

- Spaced 15 feet apart
- 225 square feet per borehole
- 400/500 feet deep
- Double and Single Loop
- 1-1/4 inch outside diameter pipe
- High Density Polyethylene

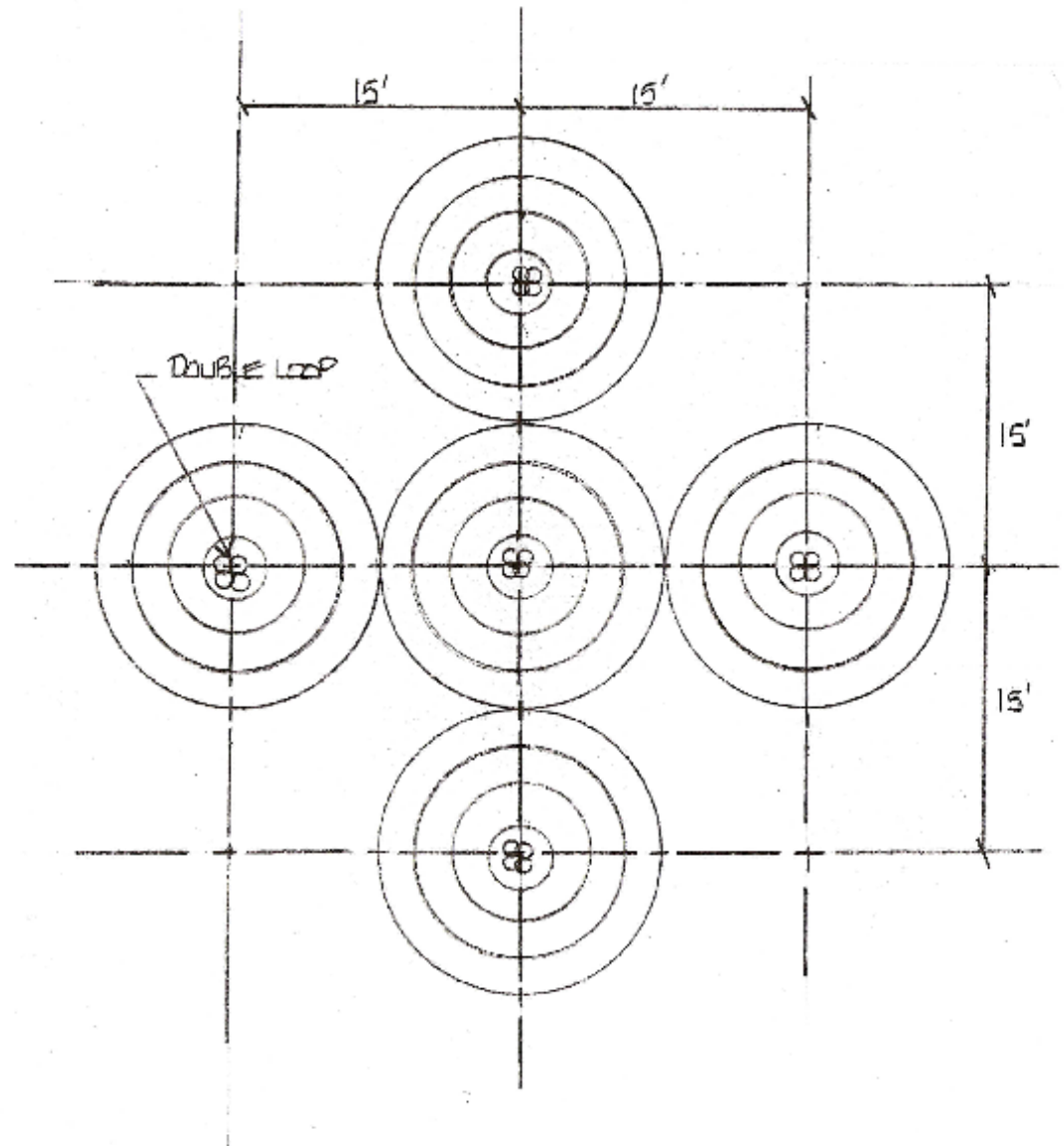

10 Year Model – Ground Temperature

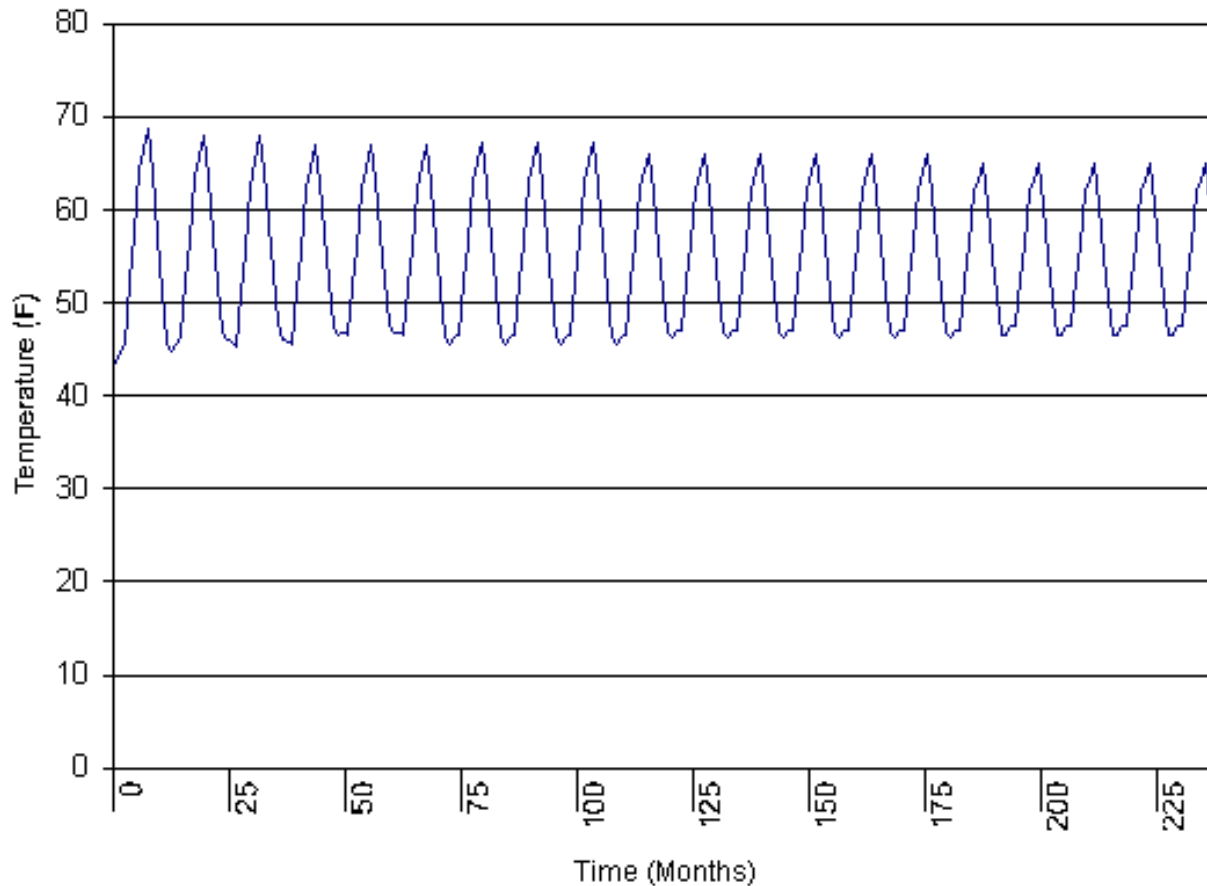

2D Resistivity Testing: Paths Across Site

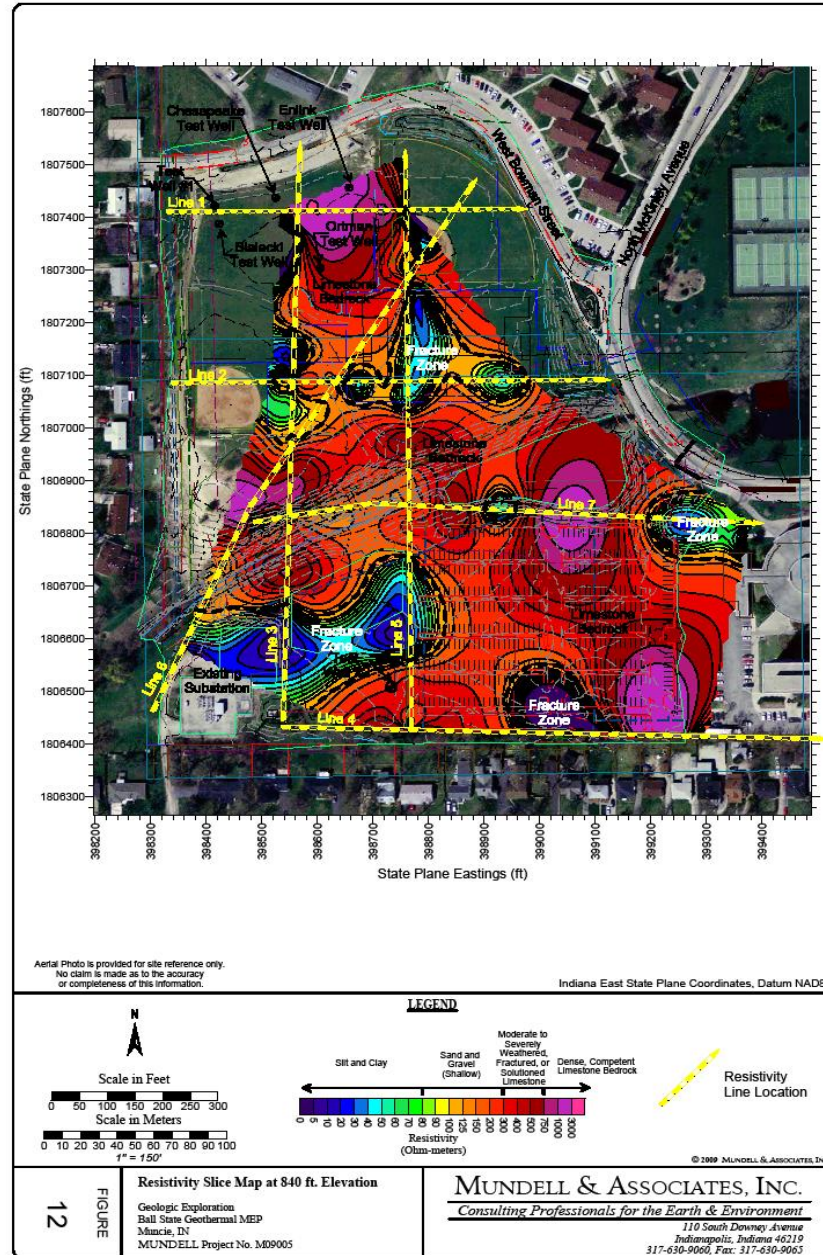

2D Cross Section

WEST

EAST

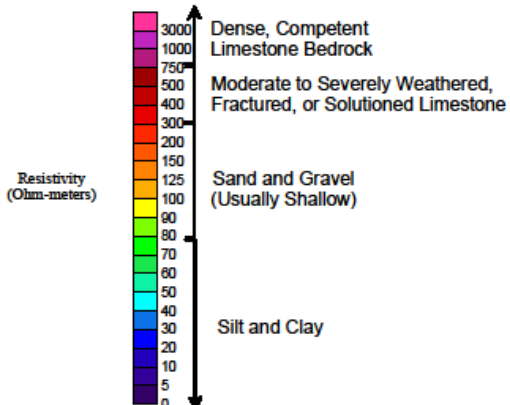
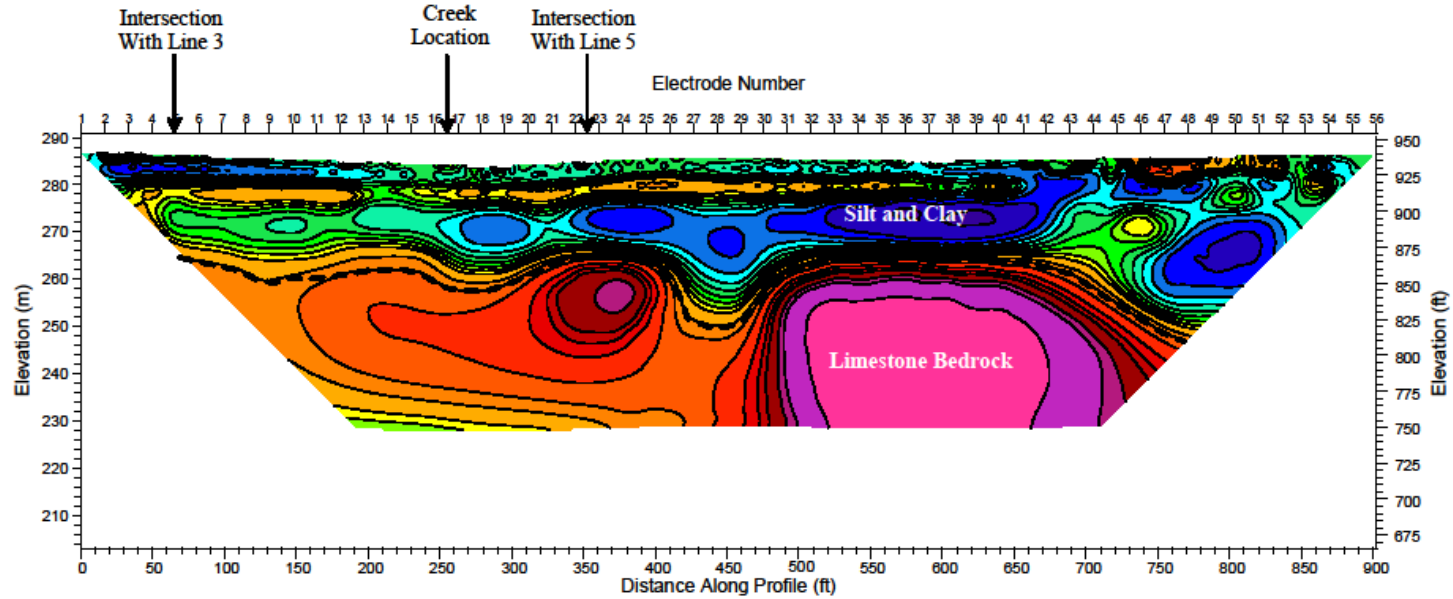

PROCESSING STATISTICS

Number of Iterations: 6
 RMS Error: 5.23%
 Total Number of Data: 648
 Maximum Misfit: 18%

<p>Line 7 Geologic Exploration Ball State University Geothermal MEP Muncie, Indiana MUNDELL Project No. M09005</p>	<p>FIGURE 8</p>
---------------------------------------------------------------------------------------------------------------------------------------------------------------------------------------------------------------	--------------------------------------

MUNDELL & ASSOCIATES, INC.
Consulting Professionals for the Earth & Environment
 110 South Downey Avenue
 Indianapolis, Indiana 46219
 317-630-9060, Fax: 317-630-9065

Senator Richard Lugar
Geothermal Groundbreaking Ceremony, May 9, 2009





Drilling Rigs

Averaged one borehole per rig per day

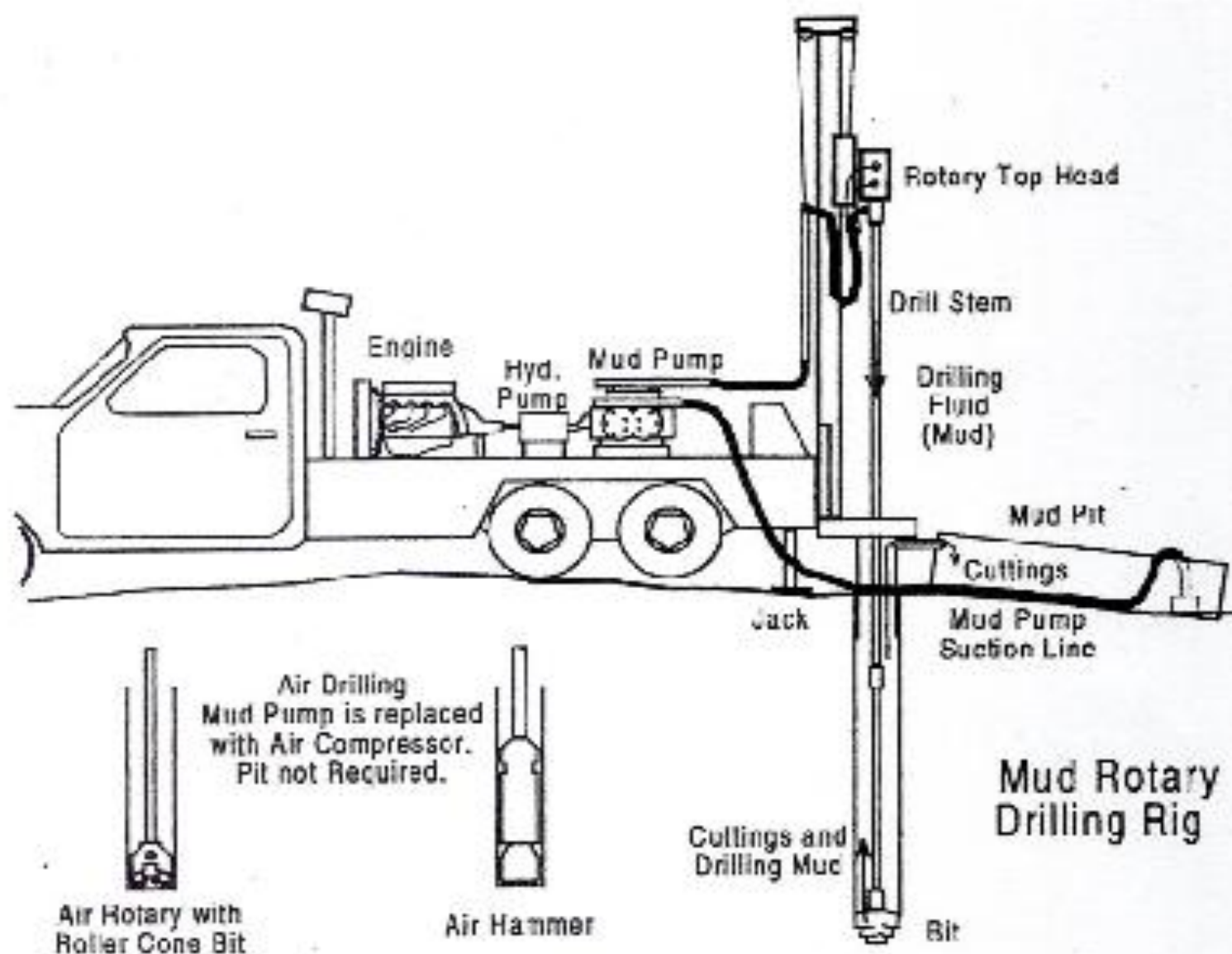

Figure C.1 Small rotary drilling rig for vertical loop installation.



Vertical Closed Loop Borehole

(2) loops: 1-1/4 diameter HDPE

Grout Tremie Line: fill pipe for bentonite and sand mixture

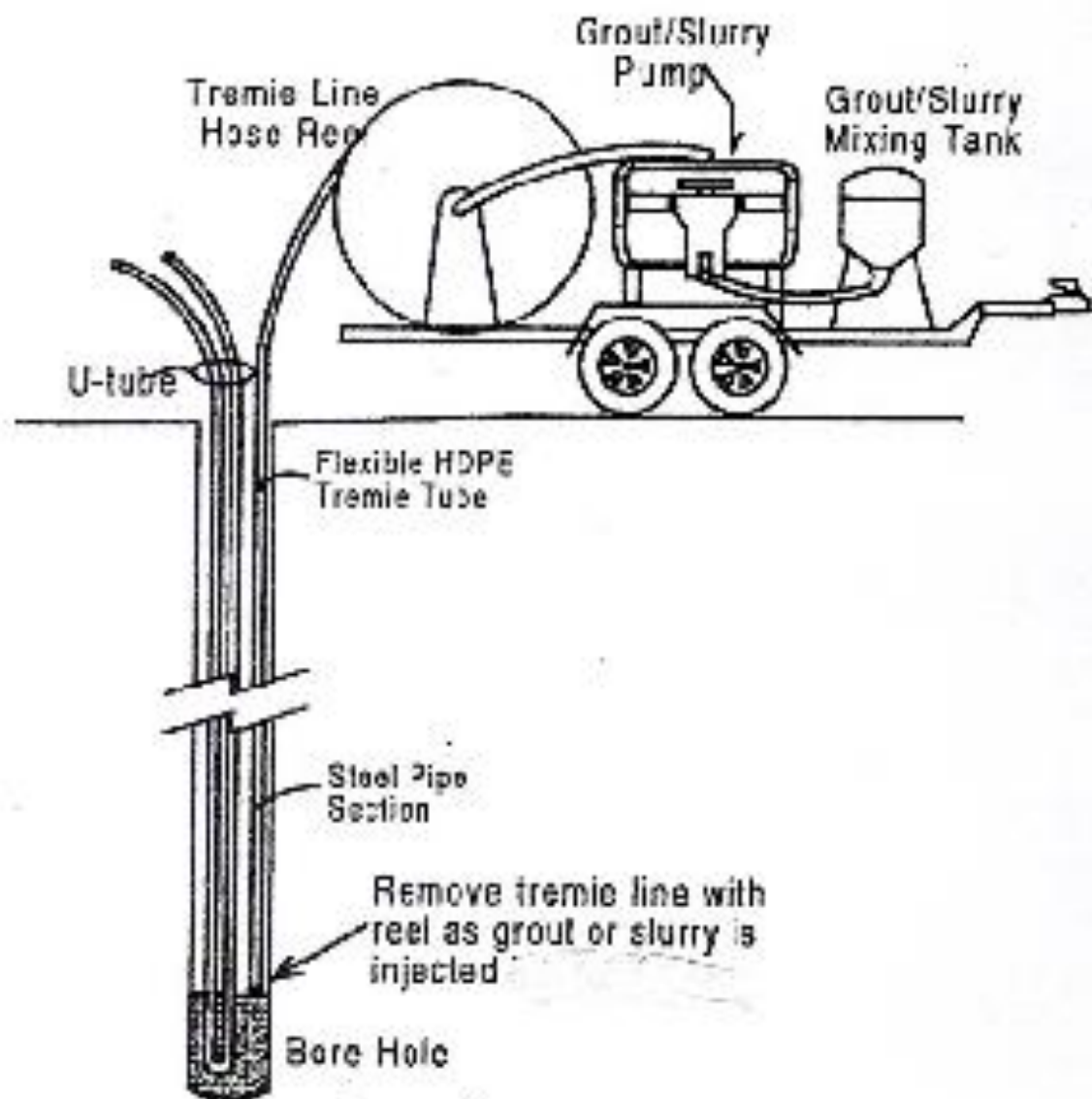

Figure C.4 Backfill/grouting the bore hole



Borehole Field

**North: 15 feet spacing
400 feet deep
Double Loop**

**South: 15 feet spacing
500 feet deep
Single Loop**

CYK York Chillers:

(4) 2,500 ton

R134A Refrigerant

150 degree F hot water

42 degree F chilled water



COP (Coefficient of Performance) = $\frac{\text{Useful work}}{\text{Input work}}$

The bigger the better!

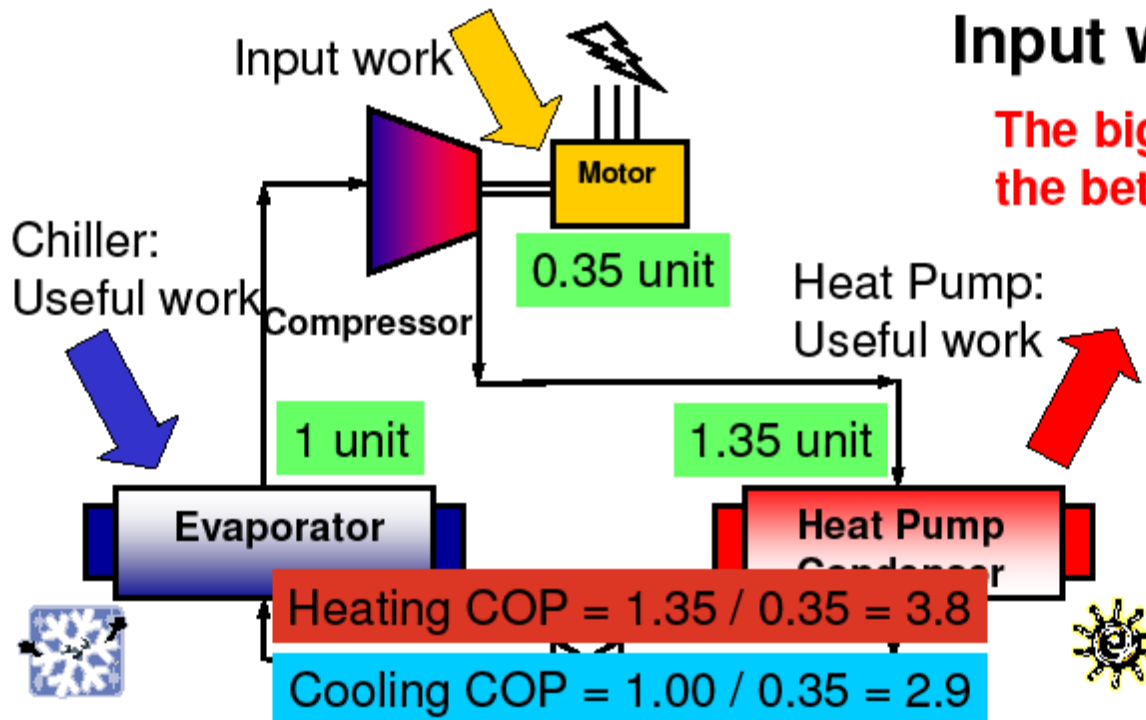



Hot Water and Chilled Water Distribution Pipe

Hot Water: Ductile Iron

Chilled Water: HDPE







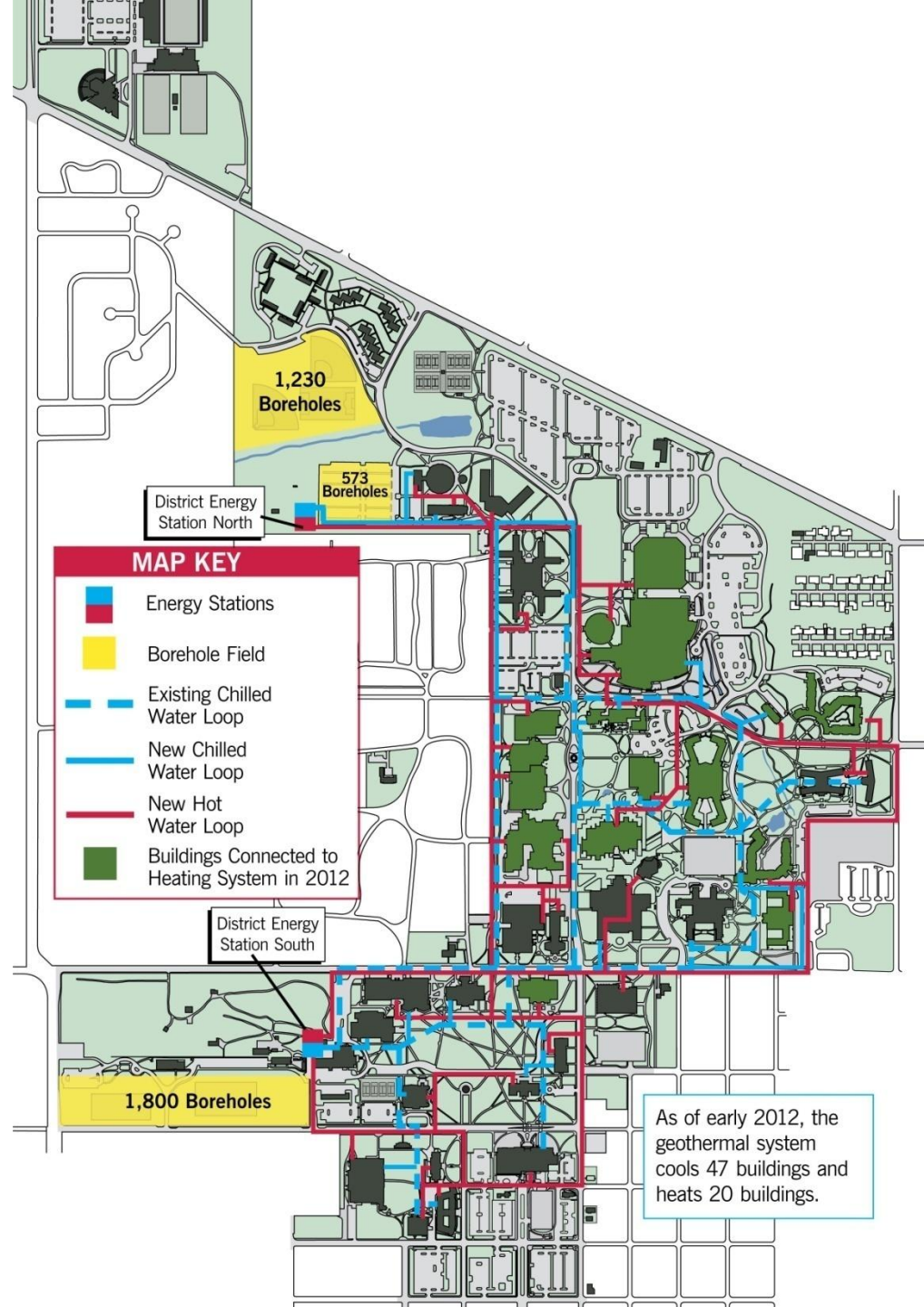

10 miles of hot water supply and return pipe



**Typical Air Handling Unit
Chilled Water Coil- 42 degree F water
Hot Water Coil- 150 degree F water**



MAP KEY

-  Energy Stations
-  Borehole Field
-  Existing Chilled Water Loop
-  New Chilled Water Loop
-  New Hot Water Loop
-  Buildings Connected to Heating System in 2012

As of early 2012, the geothermal system cools 47 buildings and heats 20 buildings.

Geothermal Conversion Cost Components

- Boreholes
- Distribution Pipe
- Building HVAC Modifications
- District Energy Buildings
- Heat Pump Chillers
- High Voltage Improvements

Estimated Construction Cost \$78-83 million

Pollutants Eliminated with Geothermal Conversion

- Carbon Dioxide 75,000 tons
- Sulfur Dioxide 1,400 tons
- Nitrogen Oxide 240 tons
- Particulate Matter 200 tons
- Carbon Monoxide 80 tons

“Ball State will be able to comply with Boiler MACT requirements”

Energy and Dollars Saved

BTUs per year reduction

500,000,000,000

40% less BTUs/SF/Year

Dollars Saved

\$2,000,000

Ball State University's Geothermal Project Visits and Inquiries

Colleges & Universities

- Dartmouth College
- Stanford University
- University of Notre Dame
- Ohio State University
- University of Iowa
- Northern Kentucky University
- Colorado College
- Slippery Rock University
- Hampton University
- Pratt Institute
- Oakland University
- Purdue University
- Miami University, Ohio
- University of Michigan
- The Evergreen State College
- Northwestern University
- University of Illinois
- Ohio University
- Lake Land College
- Indiana University-Purdue University Indianapolis
- DePauw University
- University of Washington
- Montana State University-Bozeman
- Penn State University
- University of Kentucky
- Indiana State University
- Northampton Community College

Ball State University's Geothermal Project Visits and Inquiries

- U.S. Department of Energy
- Indiana Department of Natural Resources
- Indiana Office of Energy Development
- Representatives of Isparta, Turkey
- National Wildlife Federation
- Union of Concerned Scientists
- Building Indiana Magazine
- WFYI Indiana Expeditions
- The Chronicle for Higher Education
- Delta Sky Magazine
- Second Nature
(2010 Climate Leadership Award)
- Geo Outlook Magazine
- Allison Transmission
- Waterwell Journal
- International District Energy Association
- Biz World
- The Christian Science Monitor
- National Public Radio
- Argonne National Laboratory
- National Ground Water Association
- Hoosier Environmental Council
(2010 Technology Innovator
of the Year Award)
- Waste Management
- General Service Administration

Lessons Learned: Ouch!

- Purging: separately purge each loop
- Ductile iron pipe: asphalt coating
- Borehole design: double versus single loop
- Borehole quality checks: grout conductivity
- Pressure reliefs: building interfaces
- Heat pump chillers: vary the size
- Compaction: flow fill versus vibratory roller